

|  |                          |
|--|--------------------------|
| Name: _____  | Date: _____ Event: _____ |
| City: _____ State: _____   | Track: _____             |
| Track Conditions: <input type="checkbox"/> Indoor <input type="checkbox"/> Tight <input type="checkbox"/> Smooth <input type="checkbox"/> Hard Packed <input type="checkbox"/> Blue Groove <input type="checkbox"/> Wet <input type="checkbox"/> Grass <input type="checkbox"/> Low Bite <input type="checkbox"/> High Bite<br><input type="checkbox"/> Outdoor <input type="checkbox"/> Open <input type="checkbox"/> Rough <input type="checkbox"/> Loose/Loamy <input type="checkbox"/> Dry <input type="checkbox"/> Dusty <input type="checkbox"/> Astro Turf <input type="checkbox"/> Med Bite <input type="checkbox"/> Other _____ |                          |

### Front Suspension

Toe: \_\_\_\_\_  
 Ride Height: \_\_\_\_\_ Camber: \_\_\_\_\_  
 Caster:  0°  5°  
 Kick Angle:  20°  25°  30°  
 VLA Setting:  Short Arm  Long Arm  
 Oil: \_\_\_\_\_  
 Piston: \_\_\_\_\_  
 Spring:  Standard  Low Freq. Color: \_\_\_\_\_  
 Front Pivot:  Aluminum  Plastic  HRC  
 Kick Shim:  Brass  Plastic  
 Shock Limiters: \_\_\_\_\_ Stroke: \_\_\_\_\_  
 Shock Location: \_\_\_\_\_  
 Steering Type:  Slide Rack  Bell Cranks  
 Spindle Ball Stud:  Standard  Low Mount  
 Bumper Steer Spacers: \_\_\_\_\_  
 Ackerman Ball Stud:  Standard  Low Mount  
 Ackerman Spacers: \_\_\_\_\_  
 Ackerman Arm:  #1  #2  #3  \_\_\_\_\_  
 Trail:  2mm  3mm  4mm  
 Camber Link: \_\_\_\_\_

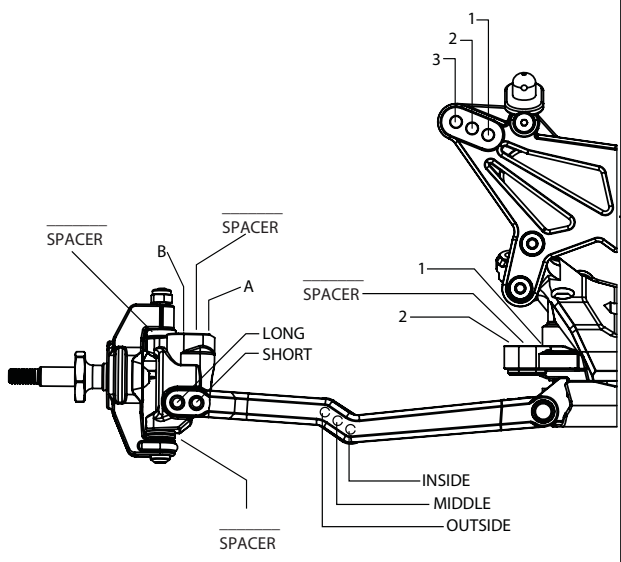

Notes: \_\_\_\_\_

\_\_\_\_\_

\_\_\_\_\_

### Rear Suspension

Transmission Type:  3-Gear  4-Gear  
 Toe Inserts:  0.5°  1°  1.5°  2°  2.5°  3°  3.5°  4°  
 Anti-Squat Inserts:  0°  0.5°  1°  1.5°  2°  2.5°  3°  
 Roll Center:  Low Roll Center (LRC)  High Roll Center (HRC)  
 Ride Height: \_\_\_\_\_ Camber: \_\_\_\_\_  
 Rear Hub Spacing: \_\_\_\_\_  
 Hex Width: \_\_\_\_\_  
 Sway Bar: \_\_\_\_\_  
 Oil: \_\_\_\_\_  
 Piston: \_\_\_\_\_  
 Spring:  Standard  Low Freq. Color: \_\_\_\_\_  
 Shock Limiters: \_\_\_\_\_ Stroke: \_\_\_\_\_  
 Shock Location: \_\_\_\_\_  
 Inner Link Spacer:  -1mm  0mm  +1mm  
 Camber Link: \_\_\_\_\_  
 Body/Spoiler: \_\_\_\_\_  
 Battery Position: \_\_\_\_\_  
 Diff Type:  Ball  Gear Setting: \_\_\_\_\_

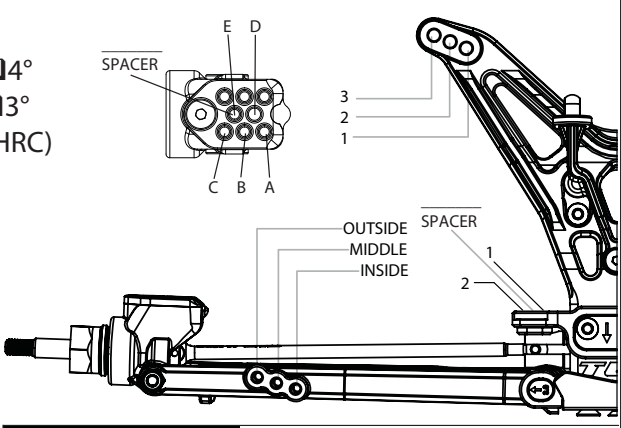

### Electronics

Radio: \_\_\_\_\_ Timing Advance: \_\_\_\_\_  
 Servo: \_\_\_\_\_ Throttle/Brake Expo: \_\_\_\_\_  
 ESC: \_\_\_\_\_ Servo Expo: \_\_\_\_\_  
 Initial Brake: \_\_\_\_\_ Throttle/Brake EPA: \_\_\_\_\_  
 Drag Brake: \_\_\_\_\_ Motor: \_\_\_\_\_  
 Throttle Profile: \_\_\_\_\_ Pinion: \_\_\_\_\_ Spur: \_\_\_\_\_  
 Battery: \_\_\_\_\_

Weight Placement (Mark with "X")

Weight of each piece \_\_\_\_\_ oz./g

| Tires:       | Compound | Insert | Additive |
|--------------|----------|--------|----------|
| Front: _____ | _____    | _____  | _____    |
| Rear: _____  | _____    | _____  | _____    |
| Notes: _____ | _____    |        |          |